

**Ikammi**

**cool  
lection  
on**

**Mastella**  
BATHROOM FURNITURE

**Kaunni  
cool  
fection  
on**

**Mastella**  
BATHROOM FURNITURE

# BALSA

Kami composition. 1	5	Kami composition. 12	55
Kami composition. 2	11	Kami composition. 13	59
Kami composition. 3	15	Kami composition. 14	65
Kami composition. 4	19	Kami composition. 15	71
Kami composition. 5	23	Kami composition. 16	77
Kami composition. 6	27	Kami composition. 17	83
Kami composition. 7	31	Kami composition. 18	87
Kami composition. 8	35	Kami composition. 19	91
Kami composition. 9	41	Kami composition. 20	95
Kami composition. 10	45	Kami composition. 21	99
Kami composition. 11	49		

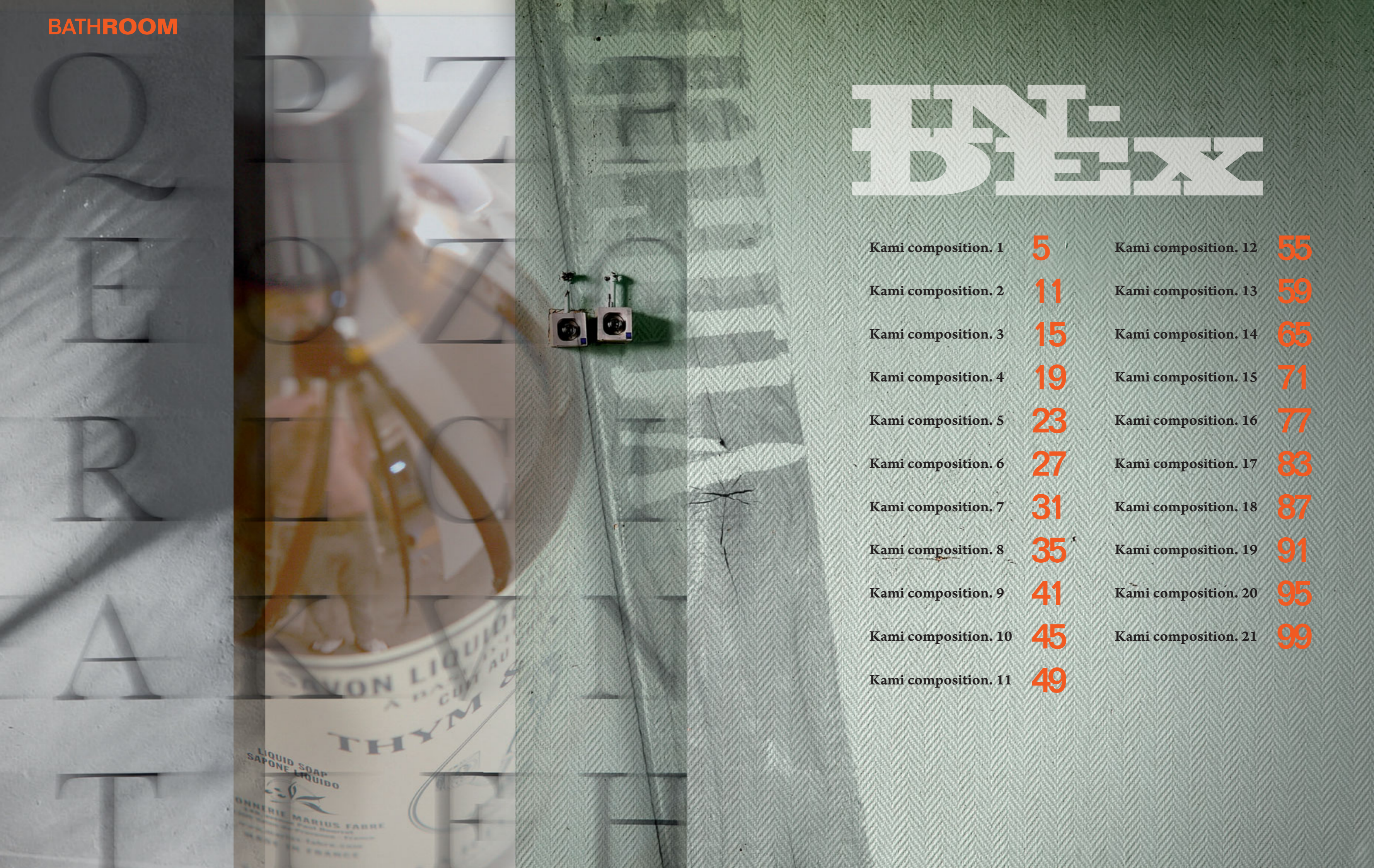

# BATHROOM

## Kami comp. 1

Design: R.&S. Mastelladesign

Composizione con doppio lavabo in Mak Mat.  
Fianchi Bianco Mat, frontali Rovere White.  
Gola Bianco Mat.  
Specchio contenitore con fianchi Bianco Mat.  
Lampada Street.

Set with double basin in Mak Mat.  
Sides in Bianco Mat, fronts in Rovere White.  
Gola Bianco Mat.  
Mirrored cabinet with sides in Bianco Mat.  
Street light.

Anlage mit Doppelwaschtisch in Mak Mat.  
Seitenteile Bianco Mat, Fronten Rovere White.  
Griffmulde Bianco Mat.  
Spiegelschrank mit Seitenteilen Bianco Mat.  
Lampe Street.

Composition avec lavabo double en Mak Mat.  
Côtés Bianco Mat, façades Rovere White.  
Gola Bianco Mat.  
Armoire de toilette à miroir avec Côtés Bianco Mat.  
Lampe Street.





Colonna con anta a specchio bifacciale  
e fianchi Bianco Mat.  
Apertura Pull-out.  
Portasalviette in ottone cromato.

Tall unit with double-sided mirrored door  
and sides in Bianco Mat.  
Pull-out opening system.  
Towel holder in chromed brass.

Hochschrank mit beidseitiger Spiegeltür  
und Seitenteilen in Bianco Mat.  
Öffnung Pull-out.  
Handtuchhalter in Messing verchromt.

Colonne avec porte miroir double face  
et côtés en Bianco Mat.  
Ouverture Pull-out.  
Porte-serviette en laiton chromé.

# positive mood.



**Kami comp. 2**

Design: R.&S. Mastelladesign

Composizione con lavabo Maxi Vov in Mak Lux.  
Top in Frassino Bianco.  
Fianchi Frassino Bianco e frontali in Frassino Moro.  
Apertura Pull-out.  
Specchio Diciotto in Frassino Moro con triled.

Set with Maxi Vov basin in Mak Lux.  
Top in Frassino Bianco.  
Sides in Frassino Bianco and fronts in Frassino Moro.  
Pull-out opening.  
Diciotto mirror with frame in Frassino Moro and triled.

Anlage mit Waschbecken Maxi Vov in Mak Lux.  
Top in Frassino Bianco.  
Seitenteile Frassino Bianco und Fronten in Frassino Moro.  
Öffnung Pull-out.  
Spiegel Diciotto in Frassino Moro mit Triled.

Composition avec lavabo Maxi Vov en Mak Lux.  
Top en Frassino Bianco.  
Côtés Frassino Bianco et façades en Frassino Moro.  
Ouverture Pull-out.  
Miroir Diciotto en Frassino Moro avec triled.





Divisori per interno cassetto in Frassino tinto nero.  
Colonna Mocap scocca in Frassino Bianco e  
schiena e frontali in Frassino Moro.

Drawer partitions in black Frassino.  
Mocap tall unit with carcass in Frassino Bianco and  
back panel and fronts in Frassino Moro.

Einteilungen für Schublade in Esche schwarz gebeizt.  
Hochschrank Mocap, Korpus in Frassino Bianco,  
Rückwand und Fronten in Frassino Moro.

Séparateurs intérieurs pour tiroir en Frassino noir.  
Colonne Mocap caisson en Frassino Bianco, dos  
et façades en Frassino Moro.

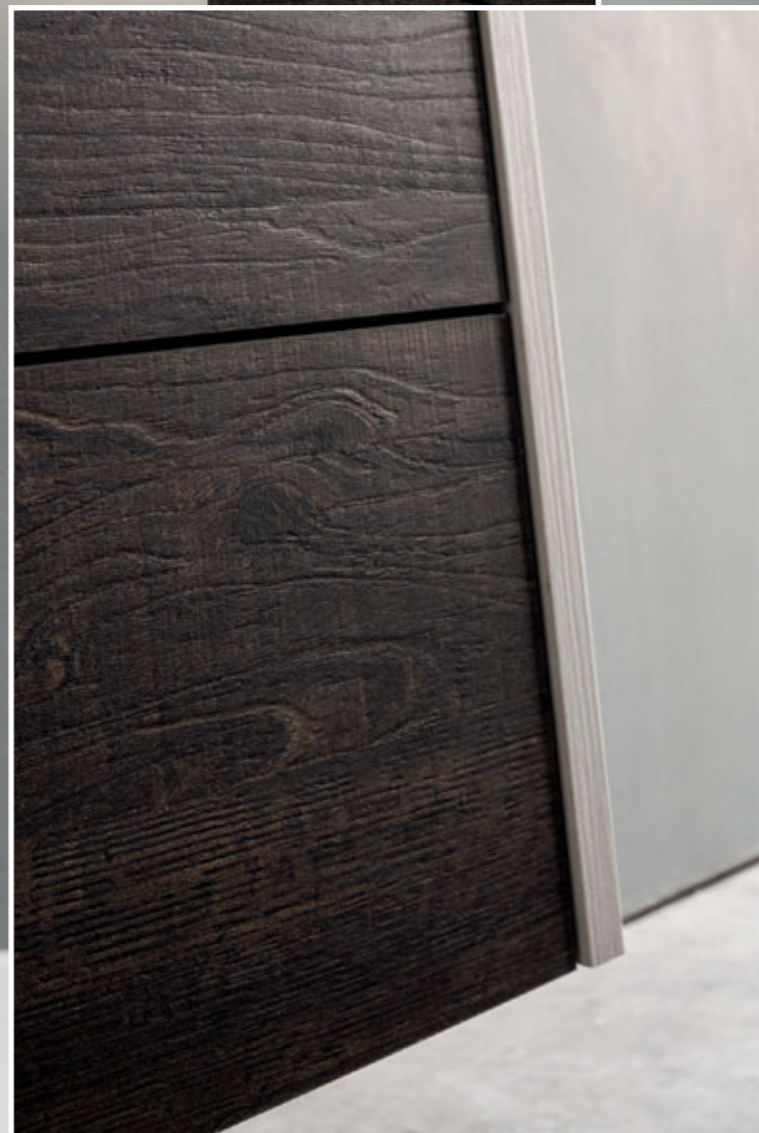
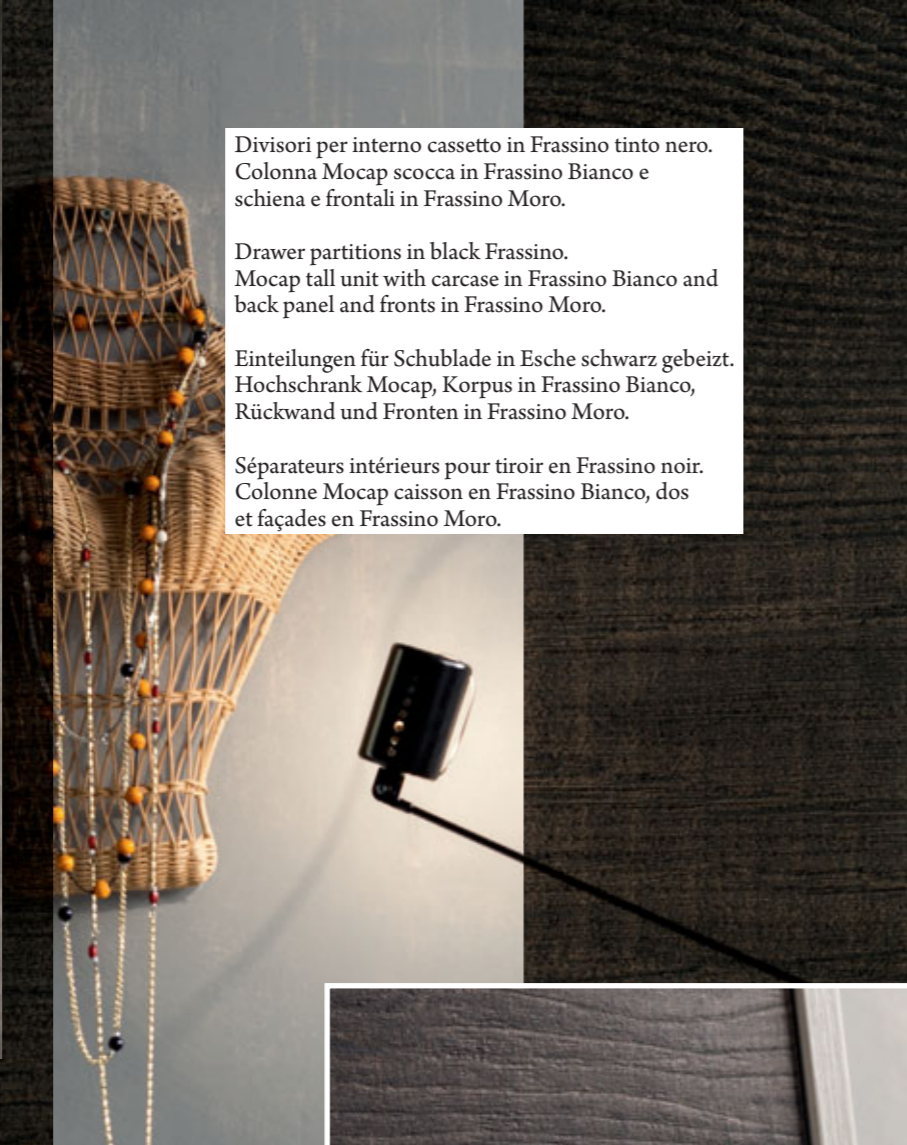





Anlage mit Halbeinbau Waschbecken Veni in Mak Lux.  
Seitenteile und Fronten Denim Mat.  
Griffmulde Denim Mat.  
Lampe Qube.

Composition avec lavabo Veni semi-encasté en Mak Lux.  
Côtés et façades Denim Mat.  
Gola Denim Mat.  
Lampe Qube.

**Kami comp. 3**  
Design: R.&S. Mastelladesign  
Composizione con lavabo Veni semincasso in Mak Lux.  
Fianchi e frontali Denim Mat.  
Gola Denim Mat.  
Lampada Qube.

Set with Vani semi-recessed basin in Mak Lux.  
Sides and fronts in Denim Mat.  
Gola Denim Mat.  
Qube light.





# bea- utiful light

Lavabo Veni semincasso in Mak Lux.  
Met in Denim Mat e Orchidea Mat.

Vani semi-recessed basin in Mak Lux.  
Met in Denim Mat and Orchidea Mat.

Halbeinbau Waschbecken Veni in Mak Lux.  
Met in Denim Mat und Orchidea Mat.

Lavabo Veni semi-encasté en Mak Lux.  
Met en Denim Mat et Orchidea Mat.



# BATHROOM

## Kami comp. 4

Design: R.&S. Mastelladesign

Composizione con lavabo Yak-In semincasso in Mak Mat.  
Fianchi e frontali Tranchè scuro.  
Specchio Filo lucido con lampada Magnetik.

Set with Yak-In recessed basin in Mak Mat.  
Sides and fronts in Tranchè scuro.  
Mirror (without bevelled edge) with Magnetik light.

Anlage mit Halbeinbau Waschbecken Yak-In in Mak Mat.  
Seitenteile und Fronten Tranchè scuro.  
Spiegel glatt poliert mit Lampe Magnetik.

Composition avec lavabo à encastrer Yak-In en Mak Mat.  
Côtés et façades Tranchè scuro.  
Miroir non biseauté avec lampe Magnetik.

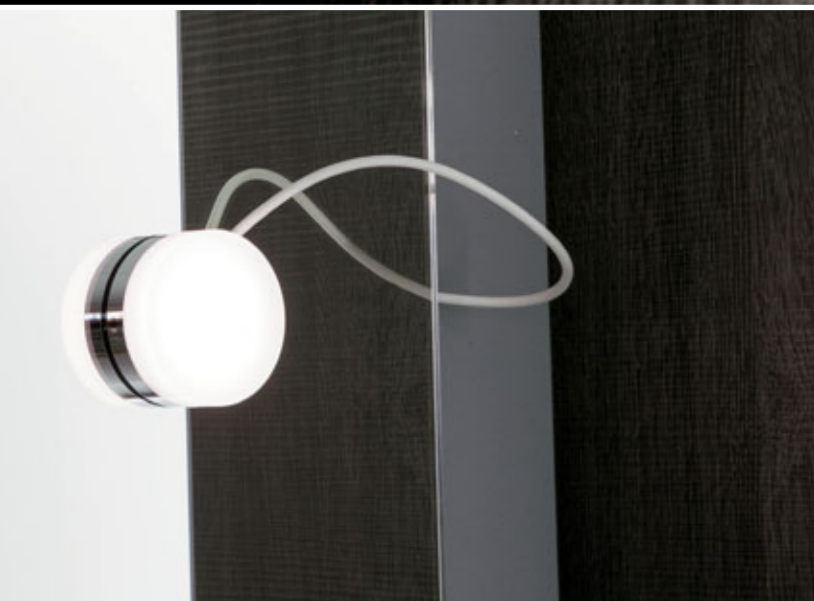

Lavabo Yak-In semincasso in Mak Mat.  
Maniglia Mimi cromo.

Yak-In recessed basin in Mak Mat.  
Handle Mimi chrome.

Halbeinbau Waschbecken Yak-In in Mak Mat.  
Griff Mimi Chrom.

Lavabo à encastrer Yak-In en Mak Mat.  
Poignée Mimi chrome.



**Kami comp. 5**

Design: R.&S. Mastelladesign

Anlage mit Glaswaschtisch Écru Sat.  
Seitenteile und Fronten Tranchè chiaro.  
Griffmulde Écru Mat.

Composizione con top-lavabo vetro Écru Sat.  
Fianchi e frontali Tranchè chiaro.  
Gola Écru Mat.

Composition avec lavabo en verre Écru Sat.  
Côtés et façades Tranchè chiaro.  
Gola Écru Mat.

Set with glass integrated basin Écru Sat.  
Sides and Fronts in Tranchè chiaro.  
Gola Écru Mat.



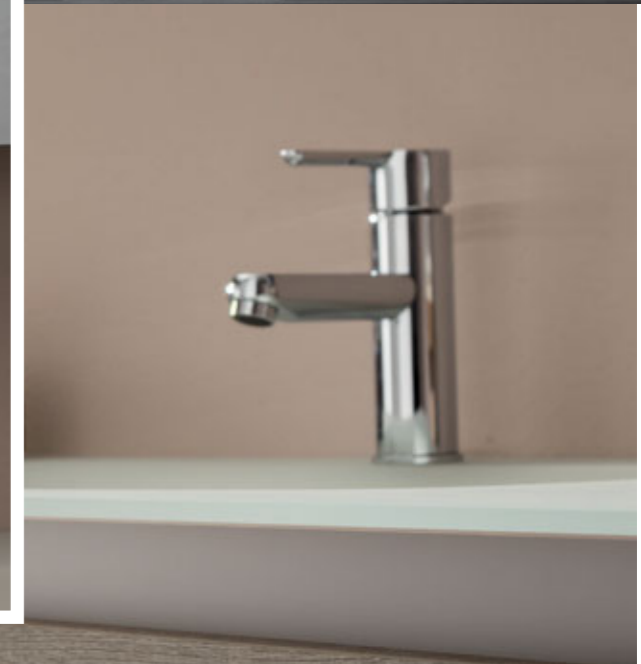

Divisori per interno cassetto in Frassino tinto nero.  
Specchio contenitore (con fianchi luminosi) Écru Mat.

Drawer partitions in black Frassino.  
Mirrored cabinet in Écru Mat (with illuminated sides).

Einteilungen für Schublade in Esche schwarz gebeizt.  
Spiegelschrank (mit beleuchteten Seitenteilen) in Écru Mat.

Séparateurs intérieurs pour tiroir en Frassino noir.  
Armoire de toilette à miroir en Écru Mat (avec cotés lumineux).

# BATHROOM



## Kami comp. 6

Design: R.&S. Mastelladesign

Composizione con top-lavabo Vinci in Mak Lux.  
Fianchi e frontali Timo Mat.  
Gola Timo Mat.  
Specchio contenitore con fianchi Timo Mat.  
Lampada Hi-line.

Set with Vinci integrated basin in Mak Lux.  
Sides and fronts in Timo Mat.  
Gola Timo Mat.  
Mirrored cabinet with Sides in Timo Mat.  
Hi-line light.

Anlage mit Waschtisch Vinci in Mak Lux.  
Seitenteile und Fronten Timo Mat.  
Griffmulde Timo Mat.  
Spiegelschrank mit Seitenteilen in Timo Mat.  
Lampe Hi-line.

Composition avec lavabo Vinci en Mak Lux.  
Côtés et façades Timo Mat.  
Gola Timo Mat.  
Armoire de toilette à miroir avec Côtés Timo Mat.  
Lampe Hi-line.

Top-lavabo Vinci in Mak Lux.

Vinci integrated basin in Mak Lux.

Waschtisch Vinci in Mak Lux.

Lavabo Vinci en Mak Lux.







Anlage mit Waschtisch Vinci in Mak Mat.  
Seitenteile in Salvia Mat und Fronten in Grafite Pino Vintage.  
Griffmulde Salvia Mat.  
Spiegelschrank mit Seitenteilen in Salvia Mat.  
Lampe Street.

Composition avec lavabo Vinci en Mak Mat.  
Côtés Salvia Mat et façades Grafite Pino Vintage.  
Gola Salvia Mat.  
Armoire de toilette à miroir avec Côtés Salvia Mat.  
Lampe Street.

**Kami comp. 7**  
Design: R.&S. Mastelladesign  
Composizione con lavabo Vinci in Mak Mat.  
Fianchi Salvia Mat e frontali Grafite Pino Vintage.  
Gola Salvia Mat.  
Specchio contenitore con fianchi Salvia Mat.  
Lampada Street.

Set with Vinci basin in Mak Mat.  
Sides in Salvia Mat and fronts in Grafite Pino Vintage.  
Gola Salvia Mat.  
Mirrored cabinet with sides in Salvia Mat.  
Street light.





Specchio contenitore con fianchi Salvia Mat.  
Lampada Street.  
Lavabo Vinci in Mak Mat.

Mirrored cabinet with sides in Salvia Mat.  
Street light.  
Vinci basin in Mak Mat.

Spiegelschrank mit Seitenteilen in Salvia Mat.  
Lampe Street.  
Waschtisch Vinci in Mitek.

Armoire de toilette à miroir avec Côtés Salvia Mat.  
Lampe Street.  
Lavabo Vinci en Mak Mat.

**Kami comp. 8**

Design: R.&S. Mastelladesign

Composizione con lavabo Dukas in Mak Mat.  
Consolle in Grafite Olmo.  
Fianchi Lino Mat e frontali Grafite Olmo  
con venatura continua e uniforme. Apertura Pull-out.  
Elemento a giorno Lino Mat.

Set with Dukas basin in Mak Mat.  
Console in Grafite Olmo.  
Sides in Lino Mat and fronts  
in Grafite Olmo with continuous  
and uniform wood grain. Pull-out opening.  
Open unit in Lino Mat.

Anlage mit Waschbecken Dukas in Mak Mat.  
Konsolle in Grafite Olmo.  
Seitenteile Lino Mat und Fronten Grafite Olmo  
mit einheitlicher Maserung. Öffnung Pull-out.  
Offenes Modul in Lino Mat.

Composition avec lavabo Dukas en Mak Mat.  
Console en Grafite Olmo.  
Côtés Lino Mat et façades Grafite Olmo  
avec venage du bois uniforme. Ouverture Pull-out.  
Module ouvert en Lino Mat.







Colonna fianchi Lino Mat e frontali Grafite Olmo con venatura continua e uniforme.  
Portasalviette su top in acciaio inox.  
Lampada Mood con luce led variabile.

Tall unit with Sides in Lino Mat and fronts in Grafite Olmo with continuous and uniform wood grain.  
Towel holder in stainless steel.  
Mood light with dimmable colour changing led.

Hochschrank mit Seitenteilen in Lino Mat und Fronten Grafite Olmo mit einheitlicher Maserung.  
Handtuchhalter auf Top in Edelstahl.  
Led Lampe Mood mit Dimmer, Lichtfarbton kalt/warm einstellbar.

Colonne avec côtés Lino Mat et façades Grafite Olmo avec venage du bois uniforme.  
Porte-serviette en acier inoxydable.  
Lampe Mood avec Led à intensité réglable.



# BATHROOM

## Kami comp. 9

Design: R.&S. Mastelladesign

Composizione con top-lavabo  
Veni semincasso in Mak Lux.  
Fianchi e frontali Lino Lux.  
Gola Lino Mat.

Set with Vani semi-recessed basin in Mak Lux.  
Sides and fronts in Lino Lux.  
Gola Lino Mat.

Anlage mit Halbeinbau Waschtisch  
Veni in Mak Lux.  
Seitenteile und Fronten Lino Lux.  
Griffmulde Lino Mat.

Composition avec lavabo Veni  
semi-encasté en Mak Lux.  
Côtés et façades Lino Lux.  
Gola Lino Mat.



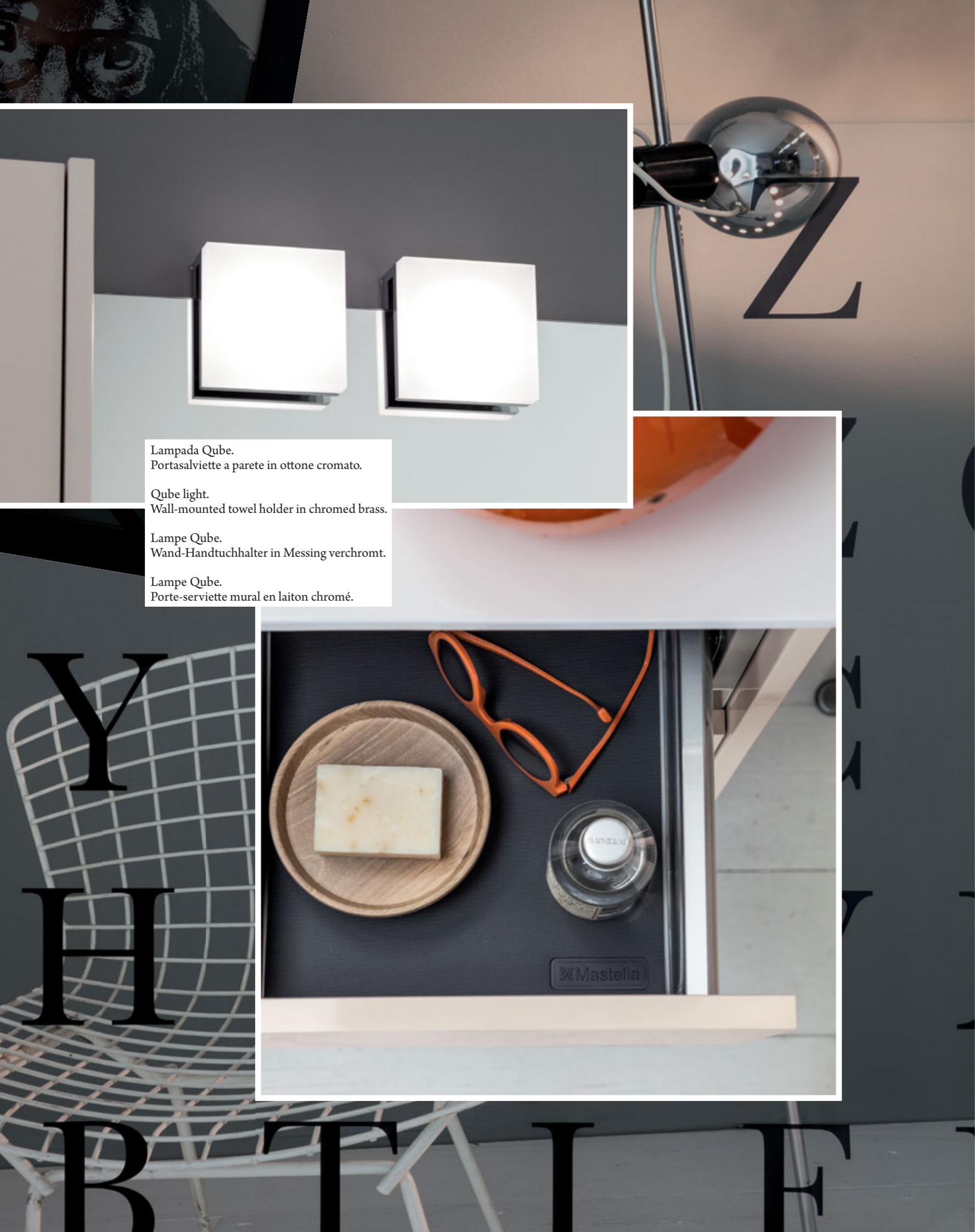

Lampada Qube.  
Portasalvietta a parete in ottone cromato.

Qube light.  
Wall-mounted towel holder in chromed brass.

Lampe Qube.  
Wand-Handtuchhalter in Messing verchromt.

Lampe Qube.  
Porte-serviette mural en laiton chromé.



# BATHROOM



## Kami comp. 10

Design: R.&S. Mastelladesign

Anlage mit Halbeinbau Waschtisch Veni in Mak Mat.  
Seitenteile und Fronten Salvia Mat.  
Öffnung Pull-out.  
Offenes Modul Van in Terracotta Mat.

Composition avec lavabo semi-encasté Veni en Mak Mat.  
Côtés et façades Salvia Mat.  
Ouverture Pull-out.  
Module ouvert Van en Terracotta Mat.

Composizione con top-lavabo Veni semincasso in Mak Mat.  
Fianchi e frontali Salvia Mat.  
Apertura Pull-out.  
Modulo aperto Van in Terracotta Mat.

Set with Vani semi-recessed basin in Mak Mat.  
Sides and fronts in Salvia Mat.  
Pull-out opening.  
Van open-storage unit in Terracotta Mat.







**Kami comp. 11**

Design: R.&S. Mastelladesign

Composizione con top-lavabo in Tecnoril.  
Fianchi e frontali Soft Pine.  
Gola Tortora Mat.  
Specchio contenitore con fianchi in Soft Pine.

Set with integrated basin in Tecnoril.  
Sides and fronts in Soft Pine.  
Gola Tortora Mat.  
Mirrored cabinet with Sides in Soft Pine.

Anlage mit Waschtisch in Tecnoril.  
Seitenteile und Fronten Soft Pine.  
Griffmulde Tortora Mat.  
Spiegelschrank mit Seitenteilen in Soft Pine.

Composition avec top-lavabo en Tecnoril.  
Côtés et façades Soft Pine.  
Gola Tortora Mat.  
Armoire de toilette à miroir avec Côtés en Soft Pine.





Top-lavabo in Tecnoril con vasca Kind con portasalviette.

Integrated basin in Tecnoril with Kind bowl and towel holder.

Waschtisch in Tecnoril mit Kind Becken und Handtuchhalter.

Lavabo intégré en Tecnoril avec vasque Kind et porte-serviette.



Lampada Giada.  
Top-lavabo in Tecnoril con vasca Kind con portasalviette.

Giada Light.  
Integrated basin in Tecnoril with Kind bowl and integrated towel holder.

Lampe Giada.  
Waschtisch in Tecnoril mit Kind Becken und Handtuchhalter.

Lampe Giada.  
Lavabo intégré en Tecnoril avec vasque Kind et porte-serviette.





## Kami comp. 12

Design: R.&S. Mastelladesign

Composizione con lavabo Ilkos in Mitek.  
Consolle in Grafite Line Gray.  
Fianchi e frontali Grigio Mat.  
Gola Grigio Mat.  
Colonna Grigio Mat con apertura Pull-out.  
Specchio Rim retroilluminato.

Set with Ilkos basin in Mitek.  
Console in Grafite Line Gray.  
Sides and fronts in Grigio Mat.  
Gola Grigio Mat.  
Tall unit in Grigio Mat with Pull-out opening system.  
Rim backlit mirror.

Anlage mit Waschbecken Ilkos in Mitek.  
Konsoleplatte in Grafite Line Gray.  
Seitenteile und Fronten Grigio Mat.  
Griffmulde Grigio Mat.  
Hochschrank in Grigio Mat mit Öffnung Pull-out.  
Spiegel Rim hinterbeleuchtet.

Composition avec lavabo Ilkos en Mitek.  
Console en Grafite Line Gray.  
Côtés et façades Grigio Mat.  
Gola Grigio Mat.  
Colonne en Grigio Mat avec ouverture Pull-out.  
Miroir Rim rétro éclairé.



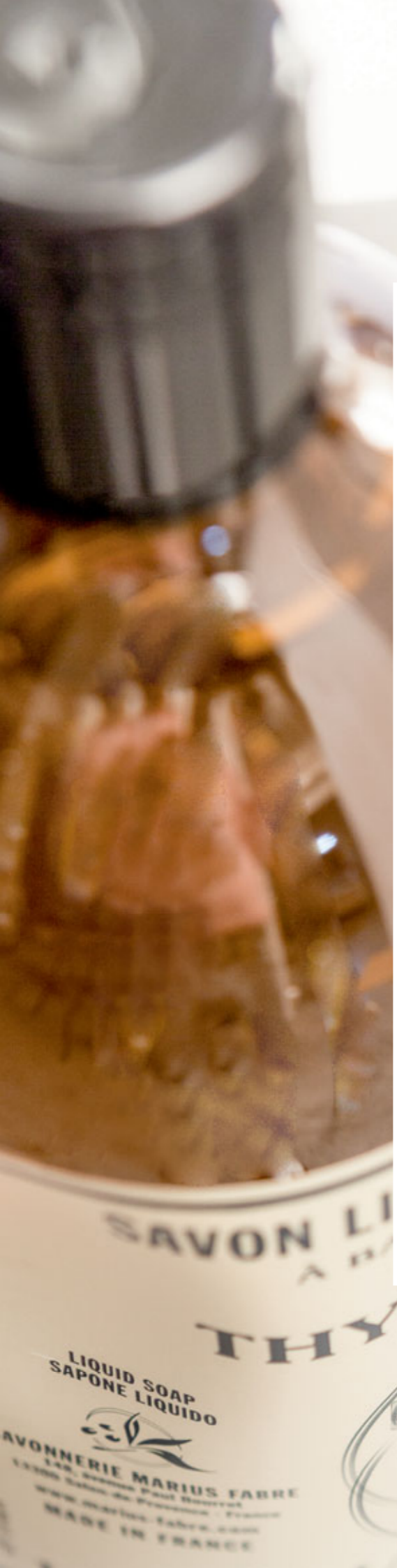



Anlage mit Waschtisch Vidi Halbeinbau in Mak Lux.  
Seitenteile und Fronten Bianco Lux.  
Öffnung Pull-out.

Composition avec lavabo semi-encasté Vidi en Mak Lux.  
Côtés et façades Bianco Lux.  
Ouverture Pull-out.

**Kami comp. 13**

Design: R.&S. Mastelladesign

Composizione con top-lavabo  
Vidi semincasso in Mak Lux.  
Fianchi e frontali Bianco Lux.  
Apertura Pull-out.

Set with Vidi semi-recessed basin in Mak Lux.  
Sides and fronts in Bianco Lux.  
Pull-out opening.









Specchio Diciotto in Rovere White con Triled.  
Top-lavabo Vidi semincasso in Mak Lux.  
Modulo aperto Van in Rovere White.

Diciotto mirror in Rovere White with triled.  
Vidi semi-recessed basin in Mak Lux.  
Van open-storage unit in Rovere White.

Spiegel Diciotto in Rovere White mit Triled.  
Halbeinbau Waschtisch Vidi in Mak Lux.  
Offenes Modul Van in Rovere White.

Miroir Diciotto en Rovere White avec Triled.  
Lavabo semi-encasté Vidi en Mak Lux.  
Module ouvert Van en Rovere White.

# BATHROOM

## Kami comp. 14

Design: R.&S. Mastelladesign

Composizione con top-lavabo Ischia sciolto H:17cm.  
Fianchi e frontali Grafite Pino Vintage.  
Gola Écru Mat.  
Pensile Mocap Écru Mat con schiena Grafite Pino Vintage.

Set with Ischia integrated basin H:17cm.  
Sides and fronts in Grafite Pino Vintage.  
Gola Écru Mat.  
Mocap unit Écru Mat with back panel in Grafite Pino Vintage.

Anlage mit Waschtisch Ischia H:17cm.  
Seitenteile und Fronten Grafite Pino Vintage.  
Griffmulde Écru Mat.  
Hängeschrank Mocap Écru Mat mit Rückwand Grafite Pino Vintage.

Composition avec lavabo Ischia H:17cm.  
Côtés et façades Grafite Pino Vintage.  
Gola Écru Mat.  
Meuble haut Mocap Écru Mat avec dos Grafite Pino Vintage.





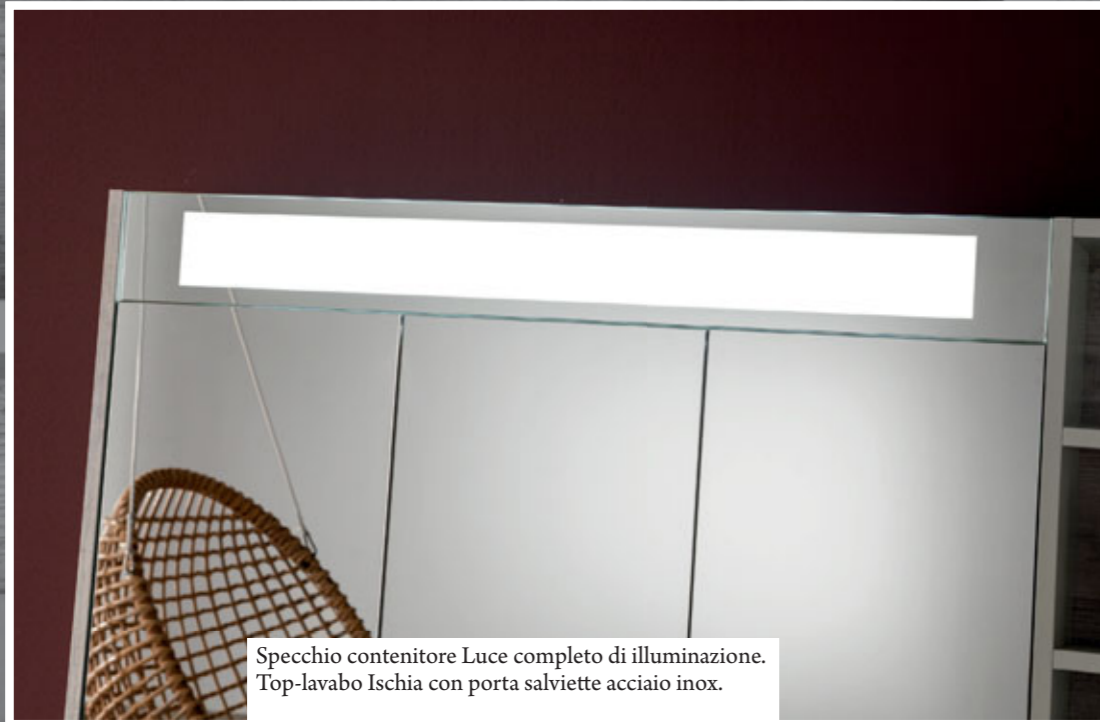

Specchio contenitore Luce completo di illuminazione.  
Top-lavabo Ischia con porta salviette acciaio inox.

Luce mirrored cabinet with integrated lighting.  
Integrated basin Ischia with stainless steel towel holder.

Spiegelschrank Luce mit Beleuchtung.  
Waschtisch Ischia mit Handtuchhalter in Edelstahl.

Armoire de toilette à miroir Luce avec éclairage.  
Lavabo Ischia avec porte-serviette en acier inoxydable.



**Kami comp. 15**

Design: R.&S. Mastelladesign

Composizione con top-lavabo Veni doppio semincasso Mak Mat.  
Fianchi Frassino Moro e frontali Frassino Moro e Petrolio Mat.  
Apertura Pull-out.  
Specchi con barra led centrale.

Set with Veni semi-recessed double basin in Mak Mat.  
Sides in Frassino Moro and fronts in  
Frassino Moro and Petrolio Mat.  
Pull-out opening.  
Mirrors with centred LED strip.

Anlage mit Halbeinbau DoppelWT Veni Mak Mat.  
Seitenteile Frassino Moro, Fronten  
Frassino Moro und Petrolio Mat.  
Öffnung Pull-out.  
Spiegel mit Led Streifen mittig.

Composition avec lavabo double semi-encasté Veni Mak Mat.  
Côtés Frassino Moro façades Frassino Moro et Petrolio Mat.  
Ouverture Pull-out.  
Miroirs avec led centrale.





Specchi con barra led centrale.  
Pensile Mocap Petrolio Mat.  
Top-lavabo Veni doppio semincasso Mak Mat.

Mirrors with centred LED strip.  
Mocap unit Petrolio Mat.  
Veni semi-recessed double basin in Mak Mat.

Spiegel mit Led Streifen mittig.  
Hängeschrank Mocap Petrolio Mat.  
Halbeinbau DoppelWT Veni Mak Mat.

Miroirs avec led centrale.  
Meuble haut Mocap Petrolio Mat.  
Lavabo double semi-encasté Veni Mak Mat.



# BATHROOM

## Kami comp. 16

Design: R.&S. Mastelladesign

Composizione con top-lavabo  
Host-Cut in Tecnoril H:1,2/17cm.  
Fianchi e frontali Tranchè chiaro.  
Gola Écru Mat.  
Specchio Giò con lampada Tend.

Set with Host-Cut integrated basin in  
Tecnoril H:1,2/17cm.  
Sides and fronts Tranchè chiaro.  
Gola Écru Mat.  
Giò mirror with Tend light.

Anlage mit Waschtisch Host-Cut in  
Tecnoril H:1,2/17cm.  
Seitenteile und Fronten Tranchè chiaro.  
Griffmulde Écru Mat.  
Spiegel Giò mit Lampe Tend.

Composition avec lavabo Host-Cut en  
Tecnoril H:1,2/17cm.  
Côtés et façades Tranchè chiaro.  
Gola Écru Mat.  
Miroir Giò avec lampe Tend.



3  
8  
10  
21  
34  
43  
46  
58  
67  
79  
81  
83  
95  
98



46  
58  
67  
79  
81  
83  
95  
98





Top-lavabo Host-Cut in Tecnoril con porta salviette acciaio inox.  
Divisori per interno cassetto in Frassino tinto nero.

Host-Cut integrated basin in Tecnoril with stainless steel towel holder.  
Drawer partitions in black Frassino.

Waschtisch Host-Cut in Tecnoril mit Handtuchhalter in Edelstahl.  
Einteilungen für Schublade in Esche schwarz gebeizt.

Lavabo Host-Cut en Tecnoril avec porte-serviette en acier inoxydable.  
Separateurs intérieurs pour tiroir en Frassino noir.



8  
10  
21  
34  
43  
46  
58  
67  
79  
81  
92



# BATHROOM



Anlage mit Waschbecken Goji in Mak Mat.  
Platte Bianco Mat 6cm Stärke.  
Seitenteile und Fronten Bianco Mat.  
Griff Tonga.  
Spiegelschrank mit Seitenteil Frassino Moro.

Composition avec lavabo Goji en Mak Mat.  
Top Bianco Mat Ép.6cm.  
Côtés et façades Bianco Mat.  
Poignée Tonga.  
Armoire de toilette à miroir avec côté Frassino Moro.

## Kami comp. 17

Design: R.&S. Mastelladesign

Composizione con lavabo Goji in Mak Mat.  
Top Bianco Mat Sp.6cm.  
Fianchi e frontali Bianco Mat.  
Maniglia Tonga.  
Specchio contenitore con fianco Frassino Moro.

Set with Goji basin in Mak Mat.  
Top in Bianco Mat (6cm).  
Sides and fronts in Bianco Mat.  
Handle Tonga.  
Mirrored cabinet with one side in Frassino Moro.





**Kami comp. 18**

Design: R.&S. Mastelladesign

Composizione con lavabo Sasso in CristalPlant.  
Top in Okite Easy Gray.  
Fianchi e frontali Écru Mat.  
Gola Écru Mat.

Set with Sasso basin in CristalPlant.  
Top in Okite Easy Gray.  
Sides and fronts in Écru Mat.  
Gola Écru Mat.

Anlage mit Waschbecken Sasso in CristalPlant.  
Top in Okite Easy Gray.  
Seitenteile und Fronten Écru Mat.  
Griffmulde Écru Mat.

Composition avec lavabo Sasso en CristalPlant.  
Top en Okite Easy Gray.  
Côtés et façades Écru Mat.  
Gola Écru Mat.





Specchio Diciotto Écru Mat con Triled.  
Divisori per interno cassetto in Frassino tinto nero.

Diciotto mirror in Écru Mat with triled.  
Drawer partitions in black Frassino.

Spiegel Diciotto Écru Mat mit Triled.  
Einteilungen für Schublade in Esche schwarz gebeizt.

Miroir Diciotto Écru Mat avec Triled.  
Séparateurs intérieurs pour tiroir en Frassino noir.



**Kami comp. 19**

Design: R.&S. Mastelladesign

Anlage mit Waschbecken Sokos in Mitek.  
Platte in Tranchè chiaro 6cm Stärke.  
Seitenteile und Fronten Seta Mat.  
Öffnung Pull-out.

Composizione con lavabo Sokos in Mitek.  
Top in Tranchè chiaro sp.6cm.  
Fianchi e frontali Seta Mat.  
Apertura Pull-out.

Composition avec lavabo Sokos en Mitek.  
Top en Tranchè chiaro Ép. 6cm.  
Côtés et façades Seta Mat.  
Ouverture Pull-out.

Set with Sokos basin in Mitek.  
Top in Tranchè chiaro (6cm).  
Sides and fronts in Seta Mat.  
Pull-out opening.





Lavabo Sokos in Mitek.  
Lampada Tend.

Sokos basin in Mitek.  
Tend light.

Waschbecken Sokos in Mitek.  
Lampe Tend.

Lavabo Sokos en Mitek.  
Lampe Tend.





**Kami comp. 20**

Design: R.&S. Mastelladesign

Composizione con lavabo Asia70 in Mitek.  
Consolle in Grafite Pino Vintage.  
Fianchi e frontali Cappuccino Mat e Lino Mat.  
Gola Cappuccino Mat e Lino Mat.

Set with Asia 70 basin in Mitek.  
Console in Grafite Pino Vintage.  
Sides and fronts in Cappuccino Mat and Lino Mat.  
Gola Cappuccino Mat and Lino Mat.

Anlage mit Waschbecken Asia70 in Mitek.  
Konsolenplatte in Grafite Pino Vintage.  
Seitenteile und Fronten Cappuccino Mat und Lino Mat.  
Griffmulde Cappuccino Mat und Lino Mat.

Composition avec lavabo Asia70 en Mitek.  
Console en Grafite Pino Vintage.  
Côtés et façades Cappuccino Mat et Lino Mat.  
Gola Cappuccino Mat et Lino Mat.





Consolle Grafite Pino Vintage.  
Pensile con ripiani vetro Cappuccino Mat.  
Apertura Pull-out.

Console Grafite Pino Vintage.  
Unit in Cappuccino Mat with glass shelves.  
Pull-out opening system.

Konsole Grafite Pino Vintage.  
Hängeschrank mit Glaseinlegeböden Cappuccino Mat.  
Öffnung Pull-out.

Console Grafite Pino Vintage.  
Meuble haut avec étagères en verre Cappuccino Mat.  
Ouverture Pull-out.



# BATHROOM

## Kami comp. 21

Design: R.&S. Mastelladesign

Composizione con top-lavabo Ischia in Tecnoril sciolto H:12cm.  
Fianchi e frontali Frassino Bianco.  
Apertura Pull-out.  
Specchio contenitore con fianco Frassino Bianco.

Set with Ischia integrated basin in Tecnoril H:12cm.  
Sides and fronts in Frassino Bianco.  
Pull-out opening.  
Mirrored cabinet with side in Frassino Bianco.

Anlage mit Waschtisch Ischia in Tecnoril H:12cm.  
Seitenteile und Fronten Frassino Bianco.  
Öffnung Pull-out.  
Spiegelschrank mit Seitenteil Frassino Bianco.

Composition avec lavabo Ischia en Tecnoril H:12cm.  
Côtés et façades Frassino Bianco.  
Ouverture Pull-out.  
Armoire de toilette à miroir avec côté en Frassino Bianco.





Pensile Mocap Frassino Bianco schiena Tortora.  
Colonna in Frassino Bianco con modulo aperto  
Van in Tortora Mat.

Mocap unit Frassino Bianco and back panel Tortora.  
Tall unit in Frassino Bianco with Van open-storage  
unit in Tortora Mat.

Hängeschränk Mocap Frassino Bianco Rückwand Tortora.  
Hochschrank in Frassino Bianco mit offenen  
Modul Van in Tortora Mat.

Meuble haut Mocap Frassino Bianco dos Tortora.  
Colonne en Frassino Bianco avec module ouvert  
Van en Tortora Mat.



BATHROOM



# STEFANO STEFANO

**Mastella**  
BATHROOM FURNITURE



Kami comp. 1 # pag. 5

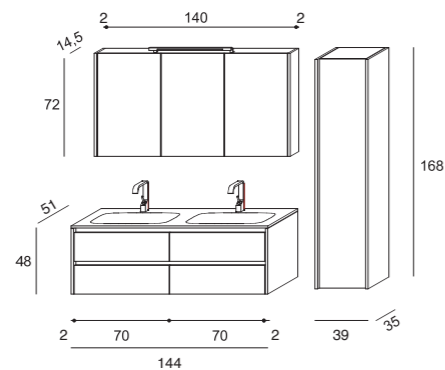

Top- lavabo in Mak Mat.  
Fianchi Bianco Mat, frontali Rovere White. Gola Bianco Mat.  
Specchio contenitore con fianchi Bianco Mat. Lampada Street.

Integrated basin in Mak Mat.  
Sides Bianco Mat, fronts Rovere White. Gola Bianco Mat.  
Mirrored cabinet with sides in Bianco Mat. Light Street.

Waschtisch in Mak Mat.  
Seiten Bianco Mat, Fronten Rovere White. Griffmulde Bianco Mat.  
Spiegelschrank mit Seiten Bianco Mat. Lampe Street.

Lavabo intégré en Mak Mat.  
Côtés Bianco Mat, façades Rovere White. Gola Bianco Mat.  
Armoire de toilette à miroir avec Côtés Bianco Mat. Lampe Street.



Kami comp. 2 # pag. 11

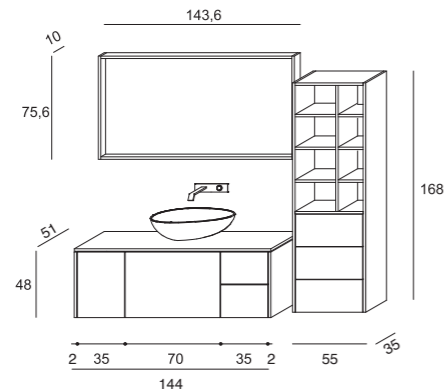

Top in Frassino Bianco sp.1,8cm. Lavabo Maxi Vov in Mak Lux.  
Fianchi Frassino Bianco e frontali in Frassino Moro. Pull-out.  
Specchio Diciotto in Frassino Moro con triled.

18 mm top in Frassino Bianco Maxi Vov basin in Mak Lux.  
Sides Frassino Bianco and fronts in Frassino Moro. Pull-out.  
Diciotto mirror in Frassino Moro with triled.

Platte in Frassino Bianco Stärke.1,8cm. Waschbecken Maxi Vov in Mak Lux.  
Seiten Frassino Bianco und Fronten in Frassino Moro. Pull-out.  
Spiegel Diciotto in Frassino Moro mit triled.

Plan en Frassino Bianco épaisseur 1,8cm Lavabo Maxi Vov en Mak Lux.  
Côtés Frassino Bianco et façades en Frassino Moro. Pull-out.  
Miroir Diciotto en Frassino Moro avec triled.



Kami comp. 3 # pag. 15

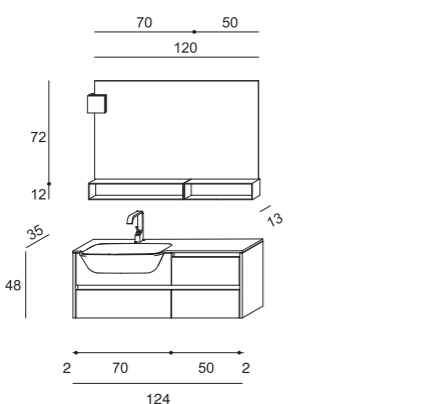

Top-lavabo Veni semincasso in Mak Lux.  
Fianchi e frontali Denim Mat. Gola Denim Mat. Lampada Qube. Specchio Bimol. Met Denim Mat-Orchidea Mat.

Veni semi-recessed basin in Mak Lux.  
Sides and fronts Denim Mat. Gola Denim Mat. Light Qube.  
Bimol mirror. Met in Denim Mat-Orchidea Mat.

Halbeinbau Waschtisch Veni in Mak Lux.  
Seiten und Fronten Denim Mat. Griffmulde Denim Mat. Lampe Qube.  
Spiegel Bimol. Met in Denim Mat-Orchidea Mat.

Lavabo Veni semi-encastré en Mak Lux.  
Côtés et façades Denim Mat. Gola Denim Mat. Lampe Qube.  
Miroir Bimol. Met en Denim Mat-Orchidea Mat.



Kami comp. 4 # pag. 19

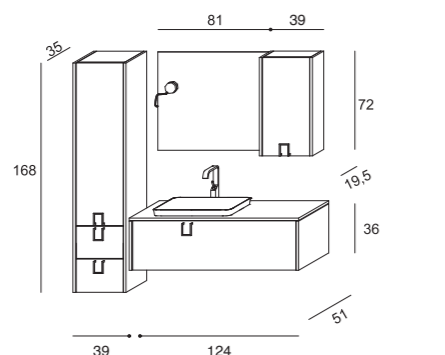

Top Tranchè scuro sp.1,8cm. Lavabo Yak-In in Mak Mat.  
Fianchi e frontali Tranchè scuro. Specchio filo lucido.  
Lampada Magnetik. Maniglia Mimi cromo.

18 mm top Tranchè scuro Lavabo Yak-In in Mak Mat.  
Sides and fronts Tranchè scuro. Mirror without bevelled edge.  
Light Magnetik. Handle Mimi chrome.

Platte Tranchè scuro Stärke 1,8cm, Waschbecken Yak-In in Mak Mat.  
Seiten und Fronten Tranchè scuro. Spiegel glatt poliert.  
Lampe Magnetik. Griff Mimi cromo.

Plan Tranchè scuro épaisseur 1,8cm Lavabo à encastrer Yak-In en Mak Mat.  
Côtés et façades Tranchè scuro. Miroir non biseauté.  
Lampe Magnetik. Poignée Mimi chrome.



Kami comp. 5 # pag. 23

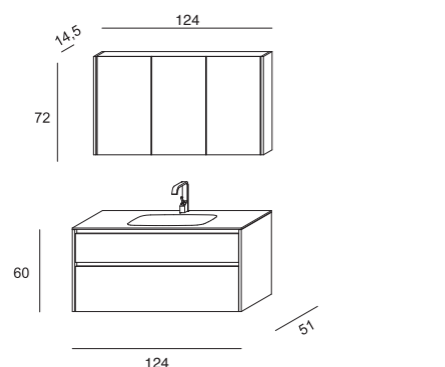

Top-lavabo in vetro Écru Sat.  
Fianchi e frontali Tranchè chiaro. Gola Écru Mat.  
Specchio contenitore con fianchi luminosi Écru Mat.

Glass integrated basin in Écru Sat.  
Sides and fronts Tranchè chiaro. Gola Écru Mat.  
Mirrored cabinet in Écru Mat with illuminated sides.

Glaswaschtisch in vetro Écru Sat.  
Seiten und Fronten Tranchè chiaro. Griffmulde Écru Mat.  
Spiegelschrank mit LED Licht Seiten Écru Mat.

Lavabo intégré en verre Écru Sat.  
Côtés et façades Tranchè chiaro. Gola Écru Mat.  
Armoire de toilette à miroir en Écru Mat avec cotés lumineux.



Kami comp. 6 # pag. 27

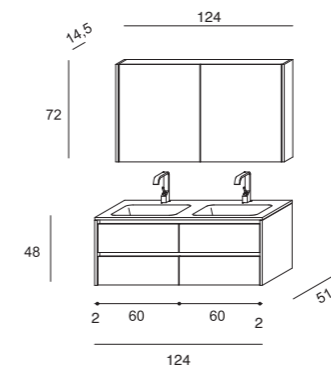

Kami comp. 7 # pag. 31

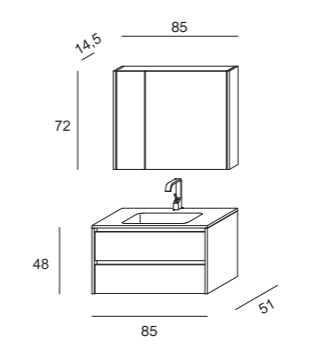

Kami comp. 8 # pag. 35

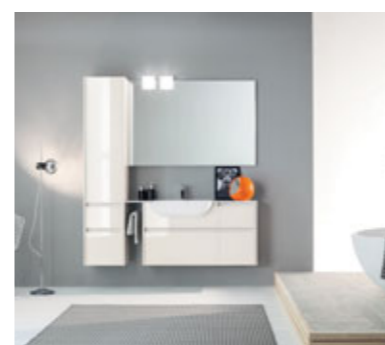
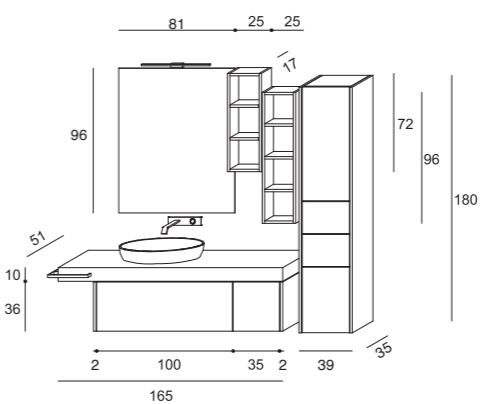

Kami comp. 9 # pag. 41

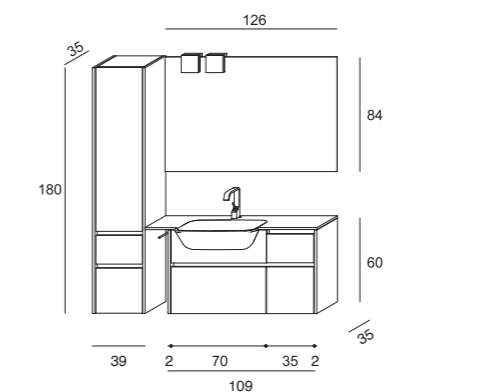

Kami comp. 10 # pag. 45

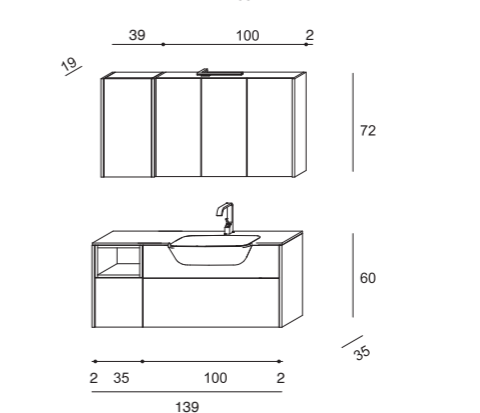

Top-lavabo Vinci in Mak Lux.  
Fianchi e frontali Timo Mat. Gola Timo Mat.  
Specchio contenitore con fianchi Timo Mat. Lampada Hi-line.

Vinci integrated basin in Mak Lux.  
Sides and fronts Timo Mat. Gola Timo Mat.  
Mirrored cabinet with sides in Timo Mat. Light Hi-line.

Waschtisch Vinci in Mak Lux.  
Seiten und Fronten Timo Mat. Griffmulde Timo Mat.  
Spiegelschrank mit Seiten Timo Mat. Lampe Hi-line.

Lavabo intégré Vinci en Mak Lux.  
Côtés et façades Timo Mat. Gola Timo Mat.  
Armoire de toilette à miroir avec Côtés Timo Mat. Lampe Hi-line.

Top-lavabo Vinci in Mak Mat.  
Fianchi Salvia Mat e frontali Pino Vintage. Gola Salvia Mat.  
Specchio contenitore con fianchi Salvia Mat. Lampada Street.

Vinci integrated basin in Mak Mat.  
Sides Salvia Mat and fronts Pino Vintage. Gola Salvia Mat.  
Mirrored cabinet with sides in Salvia Mat. Light Street.

Waschtisch Vinci in Mak Mat.  
Seiten Salvia Mat und Fronten Pino Vintage. Griffmulde Salvia Mat.  
Spiegelschrank mit Seiten Salvia Mat. Lampe Street.

Lavabo intégré Vinci en Mak Mat.  
Côtés Salvia Mat et façades Pino Vintage. Gola Salvia Mat.  
Armoire de toilette à miroir avec Côtés Salvia Mat. Lampe Street.

Console in Grafite Olmo con porta salviette.  
Lavabo Dukas in Mak Mat. Fianchi Lino Mat e frontali Grafite Olmo.  
Lampada Mood. Specchio filo lucido.

Console in Grafite Olmo with towel holder.  
Dukas basin in Mak Mat. Sides in Lino Mat and fronts in Grafite Olmo.  
Light Mood. Mirror without bevelled edge.

Konsolenplatte in Grafite Olmo mit Handtuchhalter.  
Waschbecken Dukas in Mak Mat. Seiten Lino Mat und Fronten Grafite Olmo.  
Lampe Mood. Spiegel filo lucido.

Console en Grafite Olmo avec porte-serviette.  
lavabo Dukas en Mak Mat. Côtés Lino Mat et façades Grafite Olmo.  
Lampe Mood. Miroir non biseauté.

Top-lavabo Veni in Mak Lux.  
Fianchi e frontali Lino Lux.  
Gola Lino Mat. Specchio filo lucido. Lampada Qube.

Veni semi-recessed basin in Mak Lux.  
Sides and fronts in Lino Lux.  
Gola Lino Mat. Mirror without bevelled edge. Light Qube.

Waschtisch Veni in Mak Lux.  
Seiten und Fronten Lino Lux.  
Griffmulde Lino Mat. Spiegel glatt poliert. Lampe Qube.

Lavabo Veni semi-encastré en Mak Lux.  
Côtés et façades Lino Lux.  
Gola Lino Mat. Miroir non biseauté. Lampe Qube.

Top-lavabo Veni in Mak Mat. Fianchi e frontali Salvia Mat.  
Modulo aperto Van in Terracotta Mat. Lampada Elle.  
Specchio contenitore e pensile Salvia Mat.

Veni semi-recessed basin in Mak Mat. Sides and fronts in Salvia Mat.  
Van open-storage unit in Terracotta Mat. Light Elle.  
Mirrored door cabinet and unit in Salvia Mat.

Waschtisch Veni in Mak Mat. Seiten und Fronten Salvia Mat.  
Offenes Modul Van in Terracotta Mat. Lampe Elle.  
Spiegelschrank. una Hängeschrank in Salvia Mat.

Lavabo semi-encastré Veni en Mak Mat. Côtés et façades Salvia Mat.  
Modul ouvert Van en Terracotta Mat. Lampe Elle.  
Armoire de toilette à miroir et meuble haut en Salvia Mat.



Kami comp. 11 # pag. 49

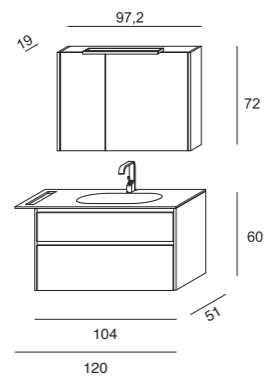

Top-lavabo in Tecnoril con vasca Kind con portasalviette. Fianchi e frontali Soft Pine. Gola Tortora Mat. Specchio contenitore con fianchi in Soft Pine. Lampada Giada.

Integrated basin in Tecnoril with Kind bowl and towel holder. Sides and fronts Soft Pine. Gola Tortora Mat. Mirrored cabinet with Sides in Soft Pine. Light Giada.

Waschtisch in Tecnoril mit Kind Becken plus Handtuchhalter. Seiten und Fronten Soft Pine. Griffmulde Tortora Mat. Spiegelschrank mit Seiten in Soft Pine. Lampe Giada.

Lavabo intégré en Tecnoril avec vasque Kind et porte-serviette. Côtés et façades Soft Pine. Gola Tortora Mat. Armoire de toilette à miroir avec Côtés en Soft Pine. Lampe Giada.



Kami comp. 12 # pag. 55

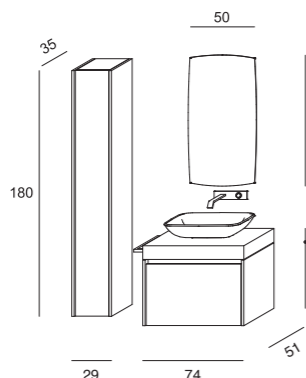

Consolle in Grafite Line Gray. Lavabo Ilkos in Mitek. Fianchi e frontali Grigio Mat. Gola Grigio Mat. Specchio Rim retroilluminato.

Console in Grafite Line Gray. Ilkos basin in Mitek. Sides and fronts Grigio Mat. Gola Grigio Mat. Rim backlit mirror.

Konsolenplatte in Grafite Line Gray. Waschbecken Ilkos in Mitek. Seiten und Fronten Grigio Mat. Griffmulde Grigio Mat. Spiegel Rim hinterbeleuchtet.

Console en Grafite Line Gray. Lavabo Ilkos en Mitek. Côtés et façades Grigio Mat. Gola Grigio Mat. Miroir Rim rétro éclairé.



Kami comp. 13 # pag. 59

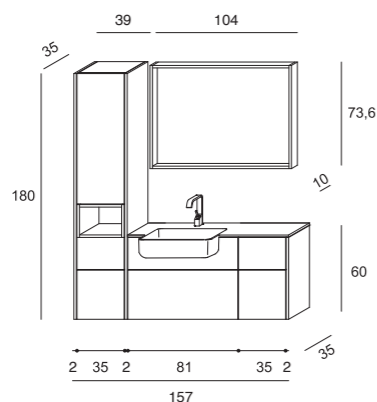

Top-lavabo Vidi semincasso in Mak Lux. Fianchi e frontali Bianco Lux. Specchio Diciotto in Rovere White con Triled. Modulo aperto Van in Rovere White.

Vidi semi-recessed basin in Mak Lux. Sides and fronts Bianco Lux. Diciotto mirror in Rovere White with Triled. Van open-storage unit in Rovere White.

Halbeinbau Waschtisch Vidi in Mak Lux. Seiten und Fronten Bianco Lux. Spiegel Diciotto in Rovere White mit Triled. Offenes Modul Van in Rovere White.

Lavabo semi-encasté Vidi en Mak Lux. Côtés et façades Bianco Lux. Miroir Diciotto en Rovere White avec Triled. Module ouvert Van en Rovere White.



Kami comp. 14 # pag. 65

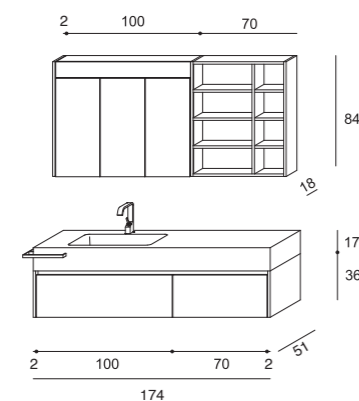

Top-lavabo Ischia H:17cm. con porta salviette. Fianchi e frontali Grafite Pino Vintage. Gola Écru Mat. Mocap Écru Mat con schiena Grafite Pino Vintage. Specchio contenitore Luce completo di illuminazione.

Ischia integrated basin H:17cm. with towel holder. Sides and fronts Grafite Pino Vintage. Gola Écru Mat. Mocap unit Écru Mat with back panel Grafite Pino Vintage. Luce mirrored cabinet with integrated lighting.

Waschtisch Ischia H:17cm. mit Handtuchhalter. Seiten und Fronten Grafite Pino Vintage. Griffmulde Écru Mat. Mocap Écru Mat mit Rückwand Grafite Pino Vintage. Spiegelschrank Luce mit Beleuchtung.

Lavabo Ischia H:17cm. avec porte-serviette. Côtés et façades Grafite Pino Vintage. Gola Écru Mat. Meuble haut Mocap Écru Mat avec dos Grafite Pino Vintage. Armoire de toilette à miroir Luce avec éclairage.



Kami comp. 15 # pag. 71

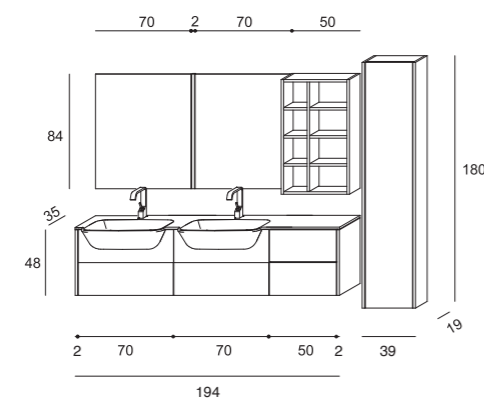

Top-lavabo Veni doppio semincasso Mak Mat. Fianchi Frassino Moro e frontali Frassino Moro e Petrolio Mat. Specchi con barra led centrale. Mocap Petrolio Mat.

Set with Veni semi-recessed double basin in Mak Mat. Sides Frassino Moro and fronts Frassino Moro and Petrolio Mat. Mirrors with centred LED strip. Mocap unit in Petrolio Mat.

Doppel- Halbeinbauwaschtisch Veni Mak Mat. Seiten Frassino Moro und Fronten Frassino Moro und Petrolio Mat. Spiegel mit mittlerem LED Streifen. Mocap Petrolio Mat.

Lavabo double semi-encasté Veni en Mak Mat. Côtés Frassino Moro et façades Frassino Moro et Petrolio Mat. Miroirs avec led centrale. Meuble haut Mocap Petrolio Mat.



Kami comp. 16 # pag. 77

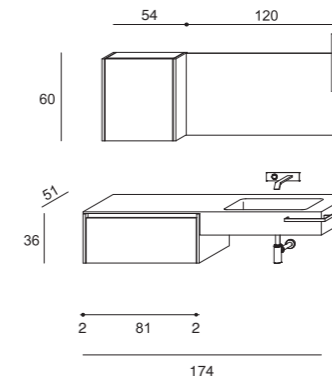

Kami comp. 17 # pag. 83

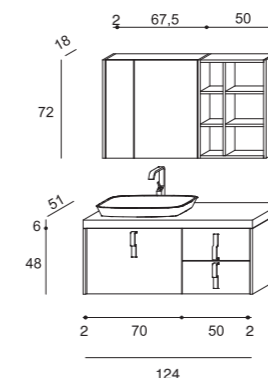

Kami comp. 18 # pag. 87

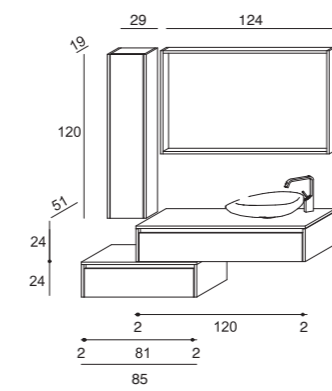

Kami comp. 19 # pag. 91

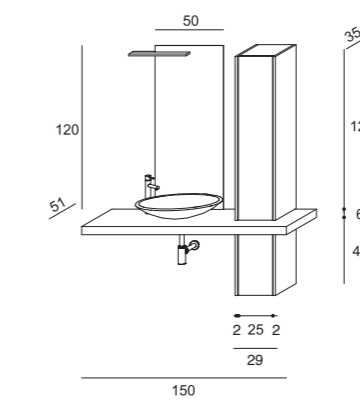

Kami comp. 20 # pag. 95

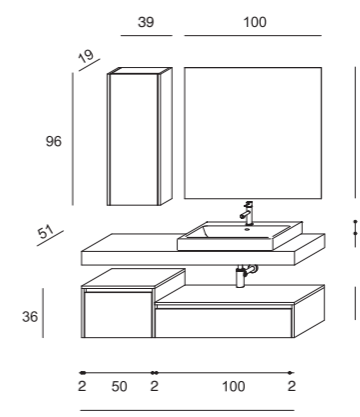

Top-lavabo Host-Cut in Tecnoril con porta salviette. Fianchi e frontali Tranchè chiaro. Gola Écru Mat. Specchio Giò. Lampada Tend.

Host-Cut integrated basin in Tecnoril with towel holder. Sides and fronts Tranchè chiaro. Gola Écru Mat. Giò mirror. Light Tend.

Waschtisch Host-Cut in Tecnoril mit Handtuchhalter. Seiten und Fronten Tranchè chiaro. Griffmulde Écru Mat. Spiegel Giò. Lampe Tend.

Lavabo Host-Cut en Tecnoril avec porte-serviette. Côtés et façades Tranchè chiaro. Gola Écru Mat. Miroir Giò. Lampe Tend.

Top Bianco Mat Sp.6cm. Lavabo Goji in Mak Mat. Fianchi e frontali Bianco Mat. Maniglia Tonga. Mocap in Frassino Moro e schiena Bianco Mat. Specchio contenitore.

6cm top Bianco Mat. Goji basin in Mak Mat. Sides and fronts Bianco Mat. Handle Tonga. Mocap unit in Frassino Moro and back in Bianco Mat. Mirrored door cabinet.

Top Bianco Mat Stärke 6cm. Waschbecken Goji in Mak Mat. Seiten und Fronten Bianco Mat. Griff Tonga. Mocap in Frassino Moro und Rückwand Bianco Mat. Spiegelschrank.

Top Bianco Mat épaisseur 6cm. Lavabo Goji en Mak Mat. Côtés et façades Bianco Mat. Poignée Tonga. Meuble haut Mocap en Frassino Moro et dos Bianco Mat. Armoire de toilette à miroir.

Top in Okite Easy Gray. Lavabo Sasso in CristalPlant. Fianchi e frontali Écru Mat. Gola Écru Mat. Specchio Diciotto Écru Mat con Triled.

Top in Okite Easy Gray. Sasso basin in CristalPlant. Sides and fronts Écru Mat. Gola Écru Mat. Diciotto mirror Écru Mat with Triled.

Top in Okite Easy Gray. Waschbecken Sasso in CristalPlant. Seiten und Fronten Écru Mat. Griffmulde Écru Mat. Spiegel Diciotto Écru Mat mit Triled.

Plan en Okite Easy Gray. Lavabo Sasso en CristalPlant. Côtés et façades Écru Mat. Gola Écru Mat. Miroir Diciotto Écru Mat avec Triled.

Top in Tranchè chiaro sp.6cm. Lavabo Sokos in Mitek. Fianchi e frontali Seta Mat. Specchio Giò-Top. Lampada Tend.

6cm top in Tranchè chiaro. Sokos basin in Mitek. Sides and fronts Seta Mat. Giò-Top mirror. Light Tend.

Top in Tranchè chiaro Stärke 6cm. Waschbecken Sokos in Mitek. Seiten und Fronten Seta Mat. Spiegel Giò-Top. Lampe Tend.

Top en Tranchè chiaro épaisseur 6cm. Lavabo Sokos en Mitek. Côtés et façades Seta Mat. Miroir Giò-Top. Lampe Tend.

Consolle in Grafite Pino Vintage. Lavabo Asia70 in Mitek. Fianchi e frontali Cappuccino Mat e Lino Mat. Gola Cappuccino Mat e Lino Mat. Specchio filo lucido senza lampada.

Console in Grafite Pino Vintage. Asia70 basin in Mitek. Sides and fronts Cappuccino Mat and Lino Mat. Gola Cappuccino Mat and Lino Mat. Mirror without bevelled edge and without light.

Konsolenplatte in Grafite Pino Vintage. Waschbecken Asia70 in Mitek. Seiten und Fronten Cappuccino Mat und Lino Mat. Griffmulde Cappuccino Mat und Lino Mat. Spiegel glatt poliert ohne Lampe.

Console en Grafite Pino Vintage. Lavabo Asia70 en Mitek. Côtés et façades Cappuccino Mat et Lino Mat. Gola Cappuccino Mat et Lino Mat. Miroir non biseauté sans lampe.



Kami comp. 21 # pag. 99

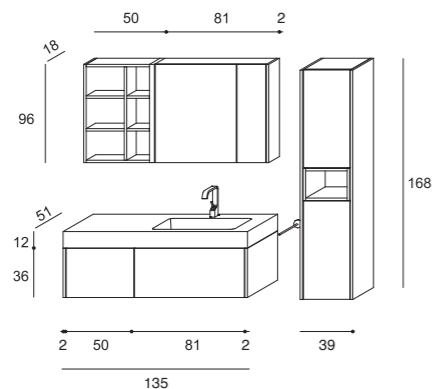

Top-lavabo Ischia in Tecnoril H:12cm.  
Fianchi e frontali Frassino Bianco.  
Specchio contenitore con fianco Frassino Bianco.  
Mocap Frassino Bianco schiena Tortora.  
Modulo aperto Van in Tortora Mat.

Ischia integrated basin in Tecnoril H:12cm.  
Sides and fronts Frassino Bianco.  
Mirrored cabinet in Frassino Bianco side.  
Mocap unit Frassino Bianco and back panel Tortora.  
Van open-storage unit in Tortora Mat.

Waschtisch Ischia in Tecnoril H:12cm.  
Seiten und Fronten Frassino Bianco.  
Spiegelschrank Seiten Frassino Bianco.  
Mocap Frassino Bianco Rückwand Tortora.  
Offenes Modul Van in Tortora Mat.

Lavabo Ischia en Tecnoril H:12cm.  
Côtés et façades Frassino Bianco.  
Armoire de toilette à miroir avec côtés Frassino Bianco.  
Meuble haut Mocap Frassino Bianco, dos Tortora.  
Module ouvert Van en Tortora Mat.

### Info tecniche generali / General technical information / Technische Informationen / Informations techniques généraux

Idropan: materiale in particelle di legno, trattato idrorepellente. Bordatura con colla poliuretanic.

Finitura legno: rivestimento melaminico.

Finitura mat: laccatura opaca satinata.

Finitura lux: laccatura lux.

Finitura Grafite: rivestimento in laminato HPL.

Finitura interna: i moduli hanno internamente la finitura in melaminico tortora.

Cassetti: struttura interna in metallo con chiusura rallentata con apertura maniglia e gola.

Ripiani interni: sono forniti di serie in vetro con reggi ripiano in metallo.

Maniglie: i moduli non prevedono alcuna maniglia di serie, nell'ordine specificare il tipo scelto.

Altezze: i moduli di serie sono forniti per essere sospesi a parete con sistema antisgancio.

Idropan: panel made of particles of water-repellent treated wood. Polyurethane glue on the edge.

Wood finish: melamine coating

Mat finish: satin mat lacquer

Lux finish: high gloss lacquer

Grafite finish: HPL coated panel sheet

Internal finish: melamine finish in Tortora colour

Drawers: metal drawer sides; soft close mechanism on units with Gola and handles

Internal shelves: glass shelves with metal brackets as standard

Handles: handle model must be specified on purchase order

Heights: standard wall-hung units with anti-fall mechanism

Idropan: wasserabweisende Spanplatte, Kantenanleimung mit Polyuretanklebstoff

Oberfläche Holz: melaminbeschichtet

Oberfläche Mat: matt satinierte Lackierung

Oberfläche Lux: Hochglanzlackierung

Oberfläche Grafite: HPL Laminat Beschichtung

Oberfläche Korpusinnenseiten: alle Module sind innen Tortora melaminbeschichtet

Schubladen: Seiten in Metall mit Soft Close System (gedämpfter Selbstzug), Öffnung mit Griff oder durch Griffmulde

Einlegeböden: aus Glas mit Metallhalterungen

Griffe: es sind keine Standardgriffe vorgesehen, diese müssen beim Auftrag mit angegeben werden.

Höhen: alle Serienmodule sind für eine Wandbefestigung mit Antiaushängungssystem vorgesehen.

Idropan: matériel de particule de bois traité hydrofuge. Bord avec colle Polyurethane.

Finition bois: revêtement mélamine.

Finition mat : laquage opaque satiné.

Finition lux: laquage brillant.

Finition perlé: laquage perlé.

Finition Grafite: revêtement en stratifié HPL.

Finition intérieure: tous les modules ont finition intérieure en mélamine couleur tortora.

Tiroirs: structure intérieure en métal avec fermeture amortie, avec poignée et avec GOLA.

Etagères intérieures: elles sont fournies standard en verre avec supports en métal.

Poignées: les modules n'ont pas une poignée standard. On doit spécifier dans la commande le model de poignée choisi.

Hauteurs: les modules standard sont fournis pour montage mural suspendus avec un système anti-décrochement.

### Finiture / Finishes / Oberflächen / Finitions

#### Legno / Wood / Holz / Bois

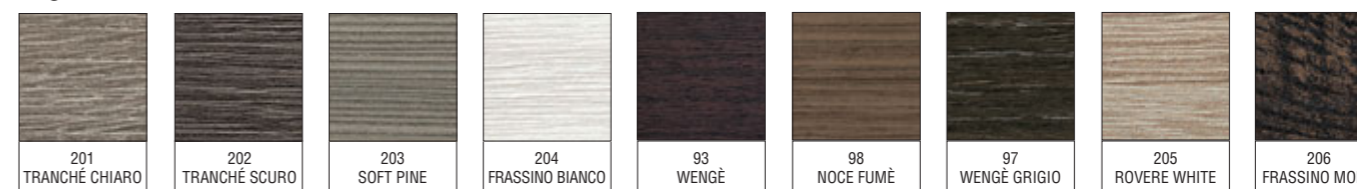

#### Colori Mat & Lux / Colours Mat & Lux / Farben Mat & Lux / Couleurs Mat & Lux



#### Colori Grafite / Grafite top colours / Farben der Platten in Grafite / Couleurs Plans Grafite

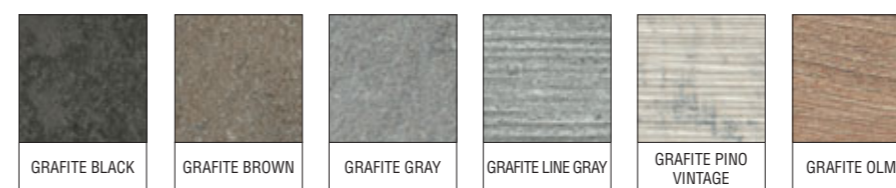

#### Colori top Okite / Okite top colours / Farben der Platten in Okite / Couleurs Plans Okite





## KAMI

Con la collezione KAMI, Mastella ha creato un sistema d'arredo dalla forte modularità; KAMI ti permette, inoltre, di creare proposte originali, incrociando finiture e materiali diversi tra scocche e frontali di una stessa composizione. Ci siamo presi cura, in questo catalogo, di proporre composizioni semplici e funzionali, ma ricercate nei materiali e nei dettagli. Abbiamo messo, anche nella collezione KAMI, la qualità al primo posto. Per Mastella la qualità di prodotto e servizio è un valore da perseguire costantemente.

With the KAMI collection, Mastella has created a fully modular furnishing system; KAMI allows you to also create original designs, combining different finishes and materials on the frames and front panels of the same composition. The compositions in this catalogue are proposed as simple and functional, yet with sought-after materials and details. Quality is also to the forefront of this KAMI collection. Mastella always prides itself in offering quality products and service.

Mit der Kollektion KAMI hat Mastella ein Einrichtungssystem mit einer starken Modularität geschaffen. Mit Kami können Sie außerdem originelle Angebote kreieren, indem verschiedene Ausführungen und Materialien mit Elementen und Frontteilen derselben Komposition kombiniert werden. Wir wollten in diesem Katalog einfache und funktionelle Kompositionen anbieten, allerdings mit ausserlesenen Materialien und Details. Auch haben wir in der Kollektion KAMI die Qualität an die erste Stelle gestellt. Für Mastella sind die Qualität des Produkts und des Kundendienstes ein stets anzustrebender Wert.

Avec la collection KAMI, Mastella a créé un système de décoration très modulable ; KAMI vous permet par ailleurs de créer des propositions originales en alliant des finitions et des matériaux différents qui se situent entre les cadres et les frontaux d'une même composition. Dans ce catalogue, nous avons été soucieux de proposer des compositions simples et fonctionnelles tout en étant recherchées au niveau des matériaux et des détails. Nous avons également mis la qualité au premier plan dans notre collection KAMI. Pour Mastella, la qualité de produit et de service est un but à atteindre continuellement.

Ottavio Mastella



Concept & Research: Mastella

Graphic & Concept: Sintony.com

Photo: Paolo Golumelli for Sintony

Styling: Anna De Ciglia

Select: Grafiche Antiga

Print: Grafiche Antiga

**SINGAPORE**

(By Equip-Bathrooms Pte Ltd)  
33 Ubi Avenue 3,  
#04-35, Vertex Tower B,  
Singapore 408868  
T: (65) 6339 5588

**JAKARTA**

(By PT Equip Concepts)  
Kompleks Harmoni Plaza, Blok J No. 20,  
Jl. Suryopranoto No. 2, Petojo Utara,  
Gambir, Jakarta Pusat 10130, Indonesia  
T: (62) 21 6385 4316

**BALI**

(By PT Equip Concepts)  
Jl. Sunset Road Barat No. 55B,  
Seminyak, Kuta-Bali 80361,  
Indonesia  
T: (62) 361 4735 036

**MALAYSIA**

(By Equip-Design & Supply Sdn Bhd)  
No. 2a-2, Jalan PJU 5/17, Dataran Sunway,  
47810 Kota Damansara, Petaling Jaya,  
Selangor Darul Ehsan, Malaysia  
T: (603) 6151 5582

E: [ilovemybathroom@equip-design.com](mailto:ilovemybathroom@equip-design.com)  
W: [www.mastella.it](http://www.mastella.it)

